



SERVING THE FOOD INDUSTRY SINCE 1951

53" Display Refrigerators, 2 Swings Glass Doors, 45 cu. ft. (1270 L) Capacity - 120V, 0.25 hp

ITEM:
MODEL:

52032
RE-CN-0045-HC-SW

53032
RE-CN-0045-HC-SB



Attract your customers with the cutting-edge appliance designed to cater to the cooling needs of commercial spaces, households, and food businesses.

With its spacious, innovative features, and durable construction, this refrigerator is the epitome of style, efficiency, and reliability.

FEATURES:

- Sleek and Durable Design
- Efficient Self-Closing Doors
- Adaptable Plastic Coated Steel Shelves
- Automatic Defrosting
- Exceptional Insulation
- Precise Temperature Control
- Robust Cooling System
- User-Friendly Specifications

Telephone: 1-800-465-0234

Fax: (905) 607-0234

Email: sales@omcan.com

Website: www.omcan.com



Authorized Dealer

2 YEARS WARRANTY
2 YEARS PARTS AND LABOUR
5 YEARS ON COMPRESSOR

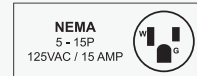

(Version 2024.07)

Page 1 / 2

TECHNICAL DRAWING

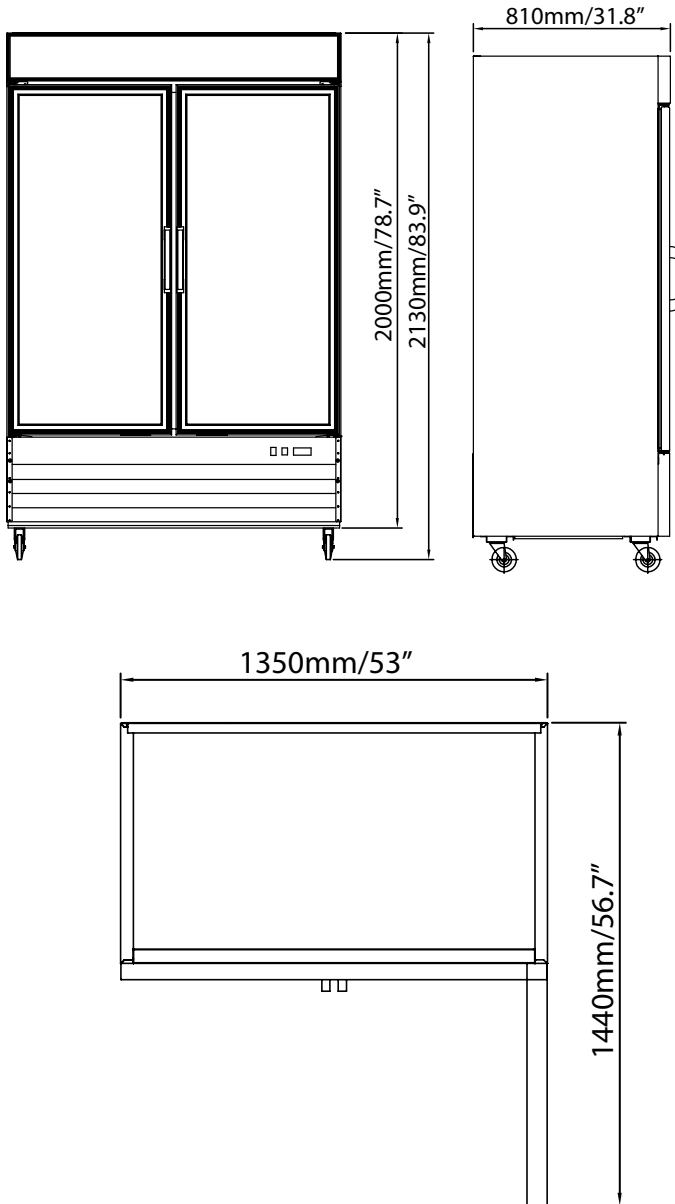

TECHNICAL SPECIFICATION

Colour	White	Black
Item	52032	53032
Model	RE-CN-0045-HC-SW	RE-CN-0045-HC-SB
Capacity	45 cu. ft. (1270 L)	
Number of Doors	2 Sliding Door - Glass Door	
Self-Closing Door	YES	
Material	Stainless steel interior and exterior, aluminum back	
Number of Shelves	8	
Shelf Capacity (kg/pc)	88 lb. (40 kg)	
Shelf Material	Plastic Coated	
Number of Casters	YES	
Power	0.25 hp	
Amps	4.3 A	
Electrical	110-120V / 60Hz / 1Ph	
Temperature Controller	Digital	
Temperature Range	0.5°C - 5°C (33°F - 41°F)	
Refrigerant	R290	
Insulation Material	Cyclopentane	
Cooling System	Ventilated	
Defrosting	Automatic	
Interior Dimensions (WDH)	50" x 28.25" x 62" (1270 x 718 x 1575 mm)	
Net Weight	441 lb. (200 kg.)	
Net Dimensions (WDH)	53" x 31.8" x 83.9" (1350 x 810 x 2130 mm)	
Gross Weight	496 lb. (225 kg.)	
Gross Dimensions (WDH)	56" x 33.5" x 84" (1422 x 851 x 2134 mm)	
Plug Type	NEMA 5-15P	